

# G15 Stainless Steel

14.8 GPM Maximum Flow Rate

1/2 inch Port Size



The G15 Series Stainless Steel Pumps are designed to provide maximum performance, while maintaining the reliability that you've grown accustomed to from Yamada. These 1/2" pumps are perfect for spraying and dispensing applications, particularly when on and off cycling reliability is critical. Utilizing our new Step Spool (S-Spool), the G15 uses up to 30% less air than the competition. Maintenance is also a breeze with fewer removeable parts. Find out today why our motto is "The Proof's in the Pump®"!

ENGINEERED TO **PERFORM.**  
DESIGNED TO **OUTLAST.**™

## Applications:



## Features & Benefits

- No lubrication required
- Stall Free / S-Spool Design
- Fewer Wearing Parts
- Ease of Repair - Quick teardown / Rebuild
- 30% less air consumption over competitor's pumps
- Perfect for dispensing and spraying applications
- Critical reliability for On/Off cycling

# G15 Stainless Steel

1/2" Port Size

14.8 GPM

## Technical Specifications

Maximum Flow Rate .....	14.8 GPM
Port Size .....	1/2" Female NPT
Air Supply Pressure .....	20-100 PSI
Liquid Temperature .....	32-212°F
Maximum Air Consumption .....	18 SCFM
Weight .....	18.1 lbs.
Maximum Size Solid .....	1/32" (1 mm)
NPT Dimensions .....	7.64" L x 6.1" W x 10.43" H
Air Inlet .....	1/4" Female NPT
Body Material .....	Stainless Steel (316)
Discharge Volume Per Cycle .....	0.039 Gallons
Dry Suction Lift .....	Rubber 15' / PTFE 12'

**Stall-Free Operation**

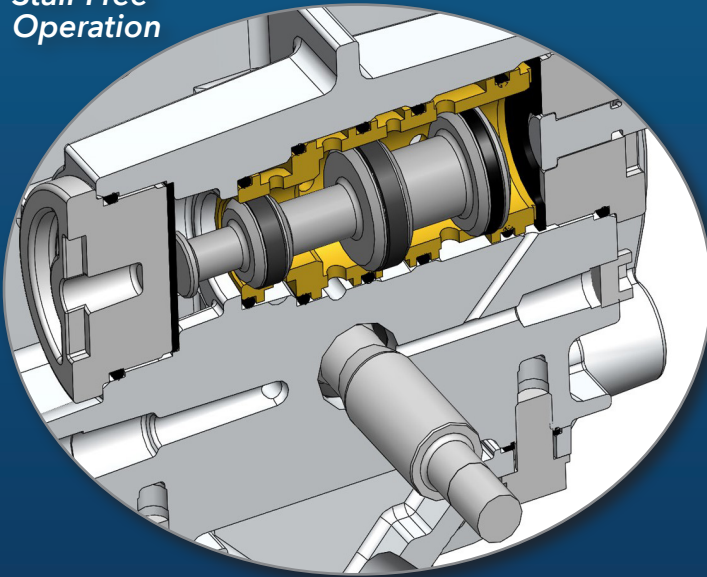

**FEWER Parts.**  
**INCREASED Reliability.**

**Step-Spool**



**Elastomeric Options**

- PTFE
- Buna N
- Santoprene®

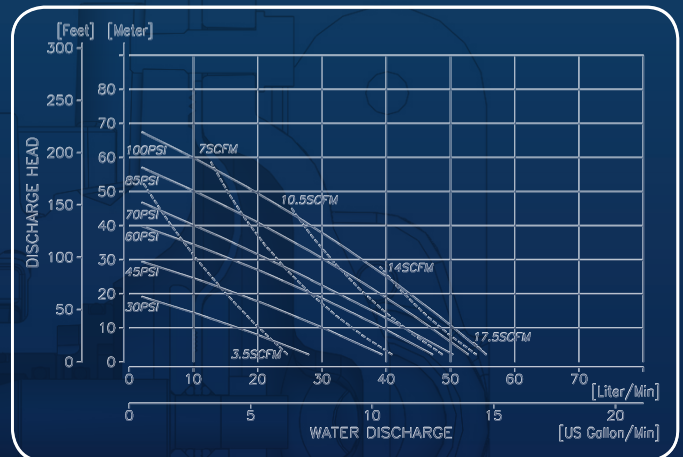

**YamadaPump.com**

**Toll Free (800) 990-7867**

Local Distributor:



Yamada® is a registered trademark of Yamada America, Inc. The Proof's in the Pump® is a registered trademark of Yamada America, Inc. The Proof is in the Pump® is a registered trademark of Yamada America, Inc. SolidPro® Designed to Pump Fluids Containing Solids is a registered trademark of Yamada America, Inc. Xtreme Duty Pro XDP® is a registered trademark of Yamada America, Inc. InkPRO® is a registered trademark of Yamada America, Inc. Santoprene® is a registered trademark of Monsanto Co. Hytrel® is a registered trademark of E.I. du Pont de Nemours and Company. Kynar® is a registered trademark of Arkema. Nordel™ is a trademark of DuPont Dow Elastomers. Ryton® is a registered trademark of Chevron Phillips Chemical Company. Viton® is a registered trademark of DuPont Performance Elastomers. Step Spool (S-Spool) C.L. 3/2/2017. Engineered to Perform. Designed to Outlast.™ is a trademark of Yamada America, Inc.

Form# G15S0219